

**TC  
142**

**MIGHTY MITE  
TUBE CHECKER**



**0  
M  
Z  
0  
0  
J  
M**

**SENCORE SERVICE MANUAL**

426 S. WESTGATE DRIVE, ADDISON, ILLINOIS

You have purchased one of the finest instruments that the electronics industry has to offer. The TCI42 is completely hand wired with no printed circuits. It has been tested completely by a competent technician and inspected twice. We know that there are many reasons why you have purchased this unit but we would like to cover all of its benefits so that you can fully appreciate them.

WHAT THE MIGHTY MITE V TESTS . . . . The Mighty Mite V will test all of the tubes used in portable radios, auto radios, Hi-Fi sets, and TV sets. It will test the newest novar, compactron, nuvistor, 10 pin and magnoval tubes. It will also check many foreign and industrial types as well. The Mighty Mite V will check over 3000 tubes. This is more tubes than any tester in this price range, and as many tubes as laboratory testers will test. Upon receipt of your signed warranty card, new listings will be sent to you as they become available, for a nominal charge of \$2.00 for each chart.

WHAT THE MIGHTY MITE V TESTS TUBES FOR . . . . A new unique principle is used in this tester that will enable you to test for leakage and gas between control grid and other elements, shorts between all elements, leakage between cathode and heater of 180,000 ohms plus the all important cathode emission test. Cathode emission has a special significance here because it serves as a positive quality check if leakage tests have been made first. In other words, it tests tubes completely. In test after test, we found that these checks have revealed troublesome tubes that other testers did not find; even expensive dynamic testers.

WHAT IS THE GRID LEAKAGE SENSITIVITY?. . . . The control grid leakage sensitivity is over 100 megohms. The high sensitivity is realized by using an expensive moving coil meter. Most testers use lower cost moving iron movements. This high sensitivity is especially important in circuits controlled by AGC voltage. A lower sensitivity of 2 to 5 megohms as found in many tube testers, may eventually reject the tube but not during the time that it is being tested because tube heat causes the leakage to increase with time. On some tubes, leakage may not reach this low level and the checkers with lower sensitivity will not find the "tough dog" tube.

HOW THE MIGHTY MITE V CHECKS EMISSION . . . . The Mighty Mite V tests all tubes for cathode emission near their operating current level (See page 7). This is very important as many testers do not test at operating levels and may test the tube good, but it will not work satisfactorily in circuit.

HOW THE MIGHTY MITE V CHECKS FOR SHORTS . . . . The Mighty Mite V contains a new unique circuit to test for shorts between each and every element in a tube. This circuit checks tubes for interelement shorts at a very low voltage. The newer "frame grid" type tubes requiring a low test voltage can be tested safely and accurately. Shorts tests are made by merely rotating Switch D through all positions while observing SHORT IND.

HOW TO CHECK HORIZONTAL OUTPUT TUBE PLATES . . . . The plate of any tube picks up very little current when measuring cathode emission. Likewise, plates or screens seldom open up. However, the horizontal output tubes with plate caps can open because of excess heat. So, it is a good idea to check the plate current separately after making the emission test. Here is how you do it:

Leave the tester set up for emission. Then, set switch B to "J" and set switch D to "K". If the plate is O. K., the meter will read. The amount of current indicated by the reading is not important as this does not change with age. It is either good or bad; open or connected. Tap the plate cap to be sure that the reading stays constant.

NEW MECHANICAL FEATURES . . . . The Mighty Mite V has a number of mechanical features not found on other tube testers. First, note that all the new sockets are provided for checking the latest tube types. Sockets have phosphor-bronze contacts for long life. The set-up chart on the inside cover with its special page holder is another handy feature. The all steel vinyl clad carrying case not only insures maximum protection but is truly modern in appearance.



TO ACQUAINT YOURSELF WITH THE MIGHTY MITE V . . . First, note the four controls market A, B, C and D. These are the four controls that you will be setting up from the chart. Next, note the twelve sockets numbered one through twelve. You will be inserting the tube in one of these sockets indicated in the chart. Locate the grid cap lead. This will be used on all tubes having grid or plate caps.

OPERATE THE TCI42 MIGHTY MITE V AS FOLLOWS:

1. Plug line cord into 105 to 125 volts 50 to 60 cycle AC receptacle.
2. Locate tube in set-up chart in cover. Tubes are listed numerically and alphabetically. Looking to the right of the tube listing, note the set-up information for controls A, B, C and D and the tube socket number. Some tubes have more than one listing. This is for tubes that effectively have more than one tube in an envelope. Each section is tested independently.
3. Set the controls as indicated and insert the tube in the socket indicated. Where more than one listing is shown, make complete checks using each listing. "Short" test need be made only once, on most tubes.

4. Set the FUNCTION switch to CAL and set the meter to the line marked CAL on the extreme right hand side of the meter by adjusting the small shaft marked CAL. You need not make this adjustment every time the tester is used, however, before rejecting a tube that is questionable, check to see that the meter is calibrated with the tube in the socket.

5. Next, switch the FUNCTION switch to the test desired. You will find some ways to short cut these tests but for a complete check, proceed as follows:

- a. Set FUNCTION switch to SHORT TEST and switch D to H-K position.
- b. SHORT IND. lamp will glow if leakage of 180,000 ohms or less exists between heater and cathode in any tube.
- c. While in the SHORT TEST position, rotate switch D through all settings from H-K to A. Watch the SHORT IND. lamp for additional shorts or leakages between elements. If the lamp glows, be sure that it glows on both electrodes. Dimly lit electrodes indicate leakage or gas in a tube. Before rejecting tube, note whether or not this tube is marked with an asterisk (\*) in the tube chart. If it is, this means that there are extra internal connections that will show up as a short and the tube should not be rejected if it lights on these settings only. Certain dual section tubes have the cathode of one section tied to the suppressor of the other section. These tubes may indicate a short on "one position only" of the "D" switch. If short is on more than one position of "D" switch, the tube has a short (unless otherwise indicated in set up booklet) and should be rejected. NOTE: A few tubes marked with an asterisk may not show shorts. This is because some tube manufacturers use the spare base pins for extra internal connections, whereas other manufacturers of the same tube type do not.

d. Set the FUNCTION switch to EMISSION if SHORTS TEST was satisfactory. Set switch D to setting indicated in chart. Read the tube emission quality on the top scale on the meter.

e. If emission check is OK, set FUNCTION switch to GRID LEAKAGE. Note the lower meter scaled GOOD-BAD and questionable (?). This important check will locate many tubes that may otherwise be passed. If the meter reads in the GOOD area but is slowly moving into the questionable area, wait for a minute or so to see if the meter will finally move into the BAD area. This is the type of tube that is hard to find on many other testers. These particular tubes may not give serious trouble in power output or rectifier stages but should be rejected immediately if operating in high impedance circuits.

If all tests have been satisfactory, the tube is in excellent condition and should not be replaced. Please note the cap lead which should be placed on all tubes having caps.



## TUBE LIFE EXPECTANCY TEST

If the meter needle climbs very slowly into the GOOD or questionable area on emission test, the life expectancy can be considered to be much less than if the meter indicated GOOD in a shorter time. Also, if the needle should climb to the GOOD area and then "fall off", life expectancy can be considered much less. We cannot recommend that you replace these tubes. That decision is up to you or your customer.

METER PROTECTION: Most tube testers have cautions about burning out the meter. The meter in the TCI42 has built-in circuit protection so that you cannot burn out the meter. With the FUNCTION SWITCH set to the "OFF" position, the meter is electrically damped. This protects it from damage due to jarring.

REJUVENATION: If you wish to rejuvenate a small tube, merely increase the filament voltage by setting switch A to one setting higher for ten or fifteen seconds. You will also find that this will accelerate gas and leakage conditions when on the GRID LEAKAGE test. If you get a grid leakage reading in the BAD area with a slight increase in filament voltage, reduce the filament setting to normal. If the leakage reading returns to GOOD, the tube is a good tube and should not be rejected. If the meter remains in the BAD area, replace the tube.

## CIRCUIT DESCRIPTION

A complete schematic of the TCI42 is shown in Figure 1.

The three major tests that determine the quality of a vacuum tube are selected with the FUNCTION control (S-5). These are cathode emission, grid leakage, and shorts between elements. The FUNCTION control also is used to turn the unit off and place a short across the meter (position 1) and to check calibration of the unit (position 5). Calibration could be compared to "Line Adjust" in some older testers.

If some trouble should develop in your tester, a few minutes spent in studying the circuit will help you to find the defect and get your tester back into operation.

## BASIC CIRCUIT

The basic indicating circuit is essentially a single ended vacuum tube voltmeter using 1/2 of a 12AU7 tube as an amplifier. Although only one tube is used, the circuit is ultra sensitive and has many outstanding features. One of the main features is the EgIp response. With zero volts on the grid (input to the 10 meg. resistor) the meter in the cathode circuit will read very low, less than 0.1 ma. As voltage is applied and gradually increased, the meter current will rise linearly until it reaches approximately 0.75 ma with +5 volts applied to the grid circuit. At this point, bias on the 12AU7 is almost zero and any additional voltage applied to grid is dropped across the 10 meg. resistor due to grid current flow. Consequently, approximately 40 volts is required to make the meter read full scale (1.0 ma). This broad response feature is used to advantage in both the emission and grid leakage tests as will be described in this section.

With the FUNCTION switch in the CAL position, i. e., approximately 40 volts at the arm of the CAL potentiometer is fed directly into the 12AU7 grid circuit. The CAL potentiometer is adjusted for full scale meter current with the tester set up and the tube to be tested in its socket.

## CATHODE EMISSION TEST

Cathode emission of a vacuum tube is tested by applying an AC voltage to the grid, or plate if the tube is a rectifier or diode, and measuring the amplitude of the pulsating DC present on the cathode. All tubes are tested at or near normal operating current levels.

The grid is used as a "pick-up" of cathode current because it was learned that nearly all current flows to the grid in testers where grid and plate are tied together. By



leaving the plate open, an emission test can be made between the grid and cathode and tests turn out the same as if the plate were connected.

The pulsating DC on the cathode of the tube under test is reduced in the voltage divider 5.6 meg. and 10 meg. and applied to the grid of the indicator circuit through 10 meg. and .01 mf. to ground. This network filters the signal so that pure DC is present on the grid of the 12AU7. A tube with normal emission will cause the meter to indicate at approximately .78 ma or 100 on the EMISSION-QUALITY scale of the meter. If emission is lower than normal, a proportionately lower meter reading will result. At 50% of normal, the meter will read in the BAD area. If emission is higher than normal, the meter indication will be compressed as described above such that it will never exceed full scale. This is an important feature, because (1) it is impossible to burn out the meter even with a shorted tube or with the load setting "B" on the wrong position and (2) it permits more usable range on the meter scale (from 0 to .75 ma).

### GRID LEAKAGE

The grid leakage test circuit uses the same basic indicating circuit. Actually, the grid leakage test circuit could be considered as an ultra sensitive ohmmeter. The break between the good and the questionable areas on the grid leakage scale represents approximately 200 megohms and the break between the questionable and the bad areas represents approximately 100 megohms.

In use, the control grid of a tube under test is connected through 10 megohms to ground. All other elements are connected to approximately +40 volts, the arm of the Calibrate adjustment control. If a tube has grid leakage or emission, a positive voltage will be developed across the 10 megohm resistor (with respect to ground) which is then fed to the 12AU7 grid and causes the meter to indicate. The more leakage there is, the higher the meter will read (towards and then into the bad area) until finally a dead short would cause the meter to read full scale. Leakage of 100 meg. or a grid emission current of approximately 0.5 microamp would produce a leakage indication just into the bad area.

### SHORT TEST

Shorts between elements of 180,000 ohms or less are indicated by a simple neon indicator. A capacitive voltage divider allows less than 35 volts to reach a tube under test. This is important, especially in the newer frame grid tubes, where breakdown can occur with higher voltages.

As switch "D" is rotated, each pin or element is checked against all of the other pins for shorts, gas, or leakage up to 180,000 ohms. In the H-K position of switch "D", heater to cathode leakage will be indicated. A dull glow indicates some leakage in a tube.

The 0.1 mf. condenser in series with the neon indicating circuit reduces the effect of normal tube conduction lighting the bulb on one anode. A "true" short will light both anodes of the bulb. Disregard dim flashes in the shorts indicator.

Note: Some tubes have internal connections between pins. These tubes will show shorts, and are indicated on the tube chart with an asterisk.

### SWITCHING AND SOCKETS

Referring to the complete schematic, Figure 1, note that all tube pins, except filaments, first go through SET-UP switch "C" and then SET-UP switch "D". Switch "C" is a special switch that has been designed to let all pin connections feed through in positions 6 and 12 but in any other position, one of the pins is opened. For example, the schematic shows all pins feeding through except the first position which is open. In number 2 position, this lead would be open, etc.

Switch "C" is used to reject one of two control grid leads, or a filament center tap that otherwise would prevent normal testing procedure.



Switch "D" is designed to select one of the remaining tube pins (the control grid, or on rectifiers or diodes, the plate) and short all of the other pins together. The selected pin and the junction of all of the other pins are used in testing emission, grid leakage and shorts as discussed above.

### ZERO ADJUSTMENT ON THE TC142 MIGHTY MITE V TESTER

It may be noted that the zero on the TC142 is not at the extreme left as it is on most meters but rather about a quarter of an inch up the scale. This is because the circuit employed is an unbalanced VTVM to accomplish the high sensitivity on grid checks.

Line voltage changes may cause the zero to fall above or below that marked on the meter. The zero potentiometer is the potentiometer located under the front panel. It is the potentiometer nearest the 12AU7A tube. If you are operating the TC142 in an area where the line voltage is far off 115 volts (where the TC142 was factory calibrated), you may suspect that the TC142 is inaccurate because the meter does not come to rest at zero. If so, check for zero and make necessary adjustments as follows:

(a) Set the line voltage at exactly 115 volts. Set the Function Switch on CAL and adjust the CAL adjustment on the front panel until the meter reads on the CAL on the meter. This is located on the far right side of the meter.

(b) Switch the function switch to the "short test" position and note the meter reading in relation to Zero. The zero is located about one-quarter of an inch from the left side of the meter. If the meter does not read zero, adjust the internal zero adjust potentiometer under the front panel (located next to the 12AU7A tube) until the meter reads on zero. The CAL control and the zero adjust control may interact with each other. If so, it may be necessary to repeat the adjustments two or three times until both fall into calibration as you switch back and forth.

### HOW TO DETERMINE CONTROL SETTINGS FOR A NEW TUBE

It is necessary to have some information on a tube before test settings can be established. The basing must be known (from a tube manual or a schematic) and also the maximum current rating of the tube. If published data is not available, the cathode current can sometimes be estimated by analysing the circuit in which the tube is used.

1. Determine the correct socket to use. Octal tubes with the heater on pins 2 and 7 are tested in socket 1, heater on pins 7 and 8 are tested in socket 2. Nine or 10 pin miniature tubes are tested in socket 3, unless the tube has several internal connections which must be isolated, in which case socket 8 might be used. Seven pin miniature tubes with the heater on pins 3 and 4 are tested in socket 4, and in socket 7 when the heater is on pins 1 and 7. Novar tubes (.040 pin diameter) are tested in socket 5, nuvistors in socket 6, loctal tubes in socket 9, compactrons in socket 10, ten pin miniature tubes (with pins on a circle) in socket 11 and magnoval tubes (.050 pin diameter) are tested in socket 12.

2. To test a tube it is necessary that the control grid for each section can be selected individually (all other elements, excluding the heater, are tied together.) If a control grid goes to more than one pin, the extra pin can be isolated with the "C" setup switch. See section on Switching and Sockets on page 5 and also the schematic, Figure 1. The control grid pin that is picked up for test is picked up with the "D" setup switch. See schematic to relate switch settings with pin numbers. On rectifiers and diodes use the "D" setup switch to pick up the plate.

Note: The "C" setup switch is also used to isolate the tap on tapped heaters, to prevent one half of the heater from receiving the full heater voltage. When the C setup switch is set to position 6, all circuits feed through and none are interrupted.

3. Determine the filament voltage required. Set the A FILAMENT switch to the correct voltage.



4. Determine the cathode current, with normal bias, from a tube manual or estimate it after analyzing the tubes usage, and set the B LOAD switch according to the chart below.

CATHODE CURRENT	SWITCH B SETTING
50 ma+	A
20-50 ma	B
15-30 ma	C
10-16 ma	D
6-12 ma	E
2- 7 ma	F
.7- 2 ma	G
.5- .8 ma	H
.5 or less	J

5. Determine the B, C and D switch settings for each section of a multisection tube.

### TC142 TROUBLE CHART

SYMPTOM	PROBABLE CAUSE	CORRECTIVE MEASURE
No meter indication on any position of function switch.	Defective 12AU7. Defective meter. Defective potentiometer.	Check tube and replace if bad. Check meter, if bad, replace. Check potentiometer and replace if defective.
Meter indicates but will not calibrate.	Defective 12AU7. Defective CAL potentiometer.	Check tube and replace if defective. Check pot. and replace if defective.
Meter can be calibrated but will not indicate emission or leakage on some sockets.	Loose connection at tube socket or at switch C or D.	Check tube socket in use and wires which feed thru each terminal on both wafers of switch C. If switch C is OK check wires connecting between switch C and switch D for a poor connection.
Short indicator glows without tube in socket in some positions of switch D when Function Switch is in "SHORTS" position.	Wire at tube sockets touching. "C" switch improperly set.	Check wiring at tube sockets. To locate short, turn TC142 on and set FUNCTION Switch in "SHORTS" position. Then move wires with a non-metallic probe until light goes out. This will locate shorted wires. Center "C" switch properly in each position.
Grid leakage measurements OK, but emission will not indicate.	Function switch. Load switch "B". Transformer.	Check switch and connections to switch. Check switch. Check transformer for opens.
Short ind. glows on one anode when testing tube for shorts.	Defective 0.1 mf. condenser.	Check for shorted or leaky capacitor.
Meter reads above 0 on emission scale with no tube in socket.	Zero adj. pot. mis-adjusted or defective. Line voltage very low.	Check pot; re-adjust pot.
Bad tubes indicate very good (full scale).	Open resistor on load switch. Open connection at load switch or function switch.	Locate open resistor and replace. Locate open connection.

# SERVICE AND WARRANTY

All Sencore products are guaranteed to be free of defects due to workmanship when purchased. Any defective unit returned to the factory service department at 426 S. Westgate, Addison, Ill., within 90 days after purchase will be serviced free of charge. In no case will a unit be replaced with a new unit. All Warranty Cards must be in the factory office within 10 days after purchase of the unit.

Any unit that has been mishandled or misused will receive a charge for both parts and labor regardless of date of purchase.

No unit will be serviced without charge for either parts or labor after one year of manufacture regardless of circumstances. Run numbers are stamped on chassis to denote date of manufacture.

Please tell us what you think is wrong with the unit when you send it in for repair.

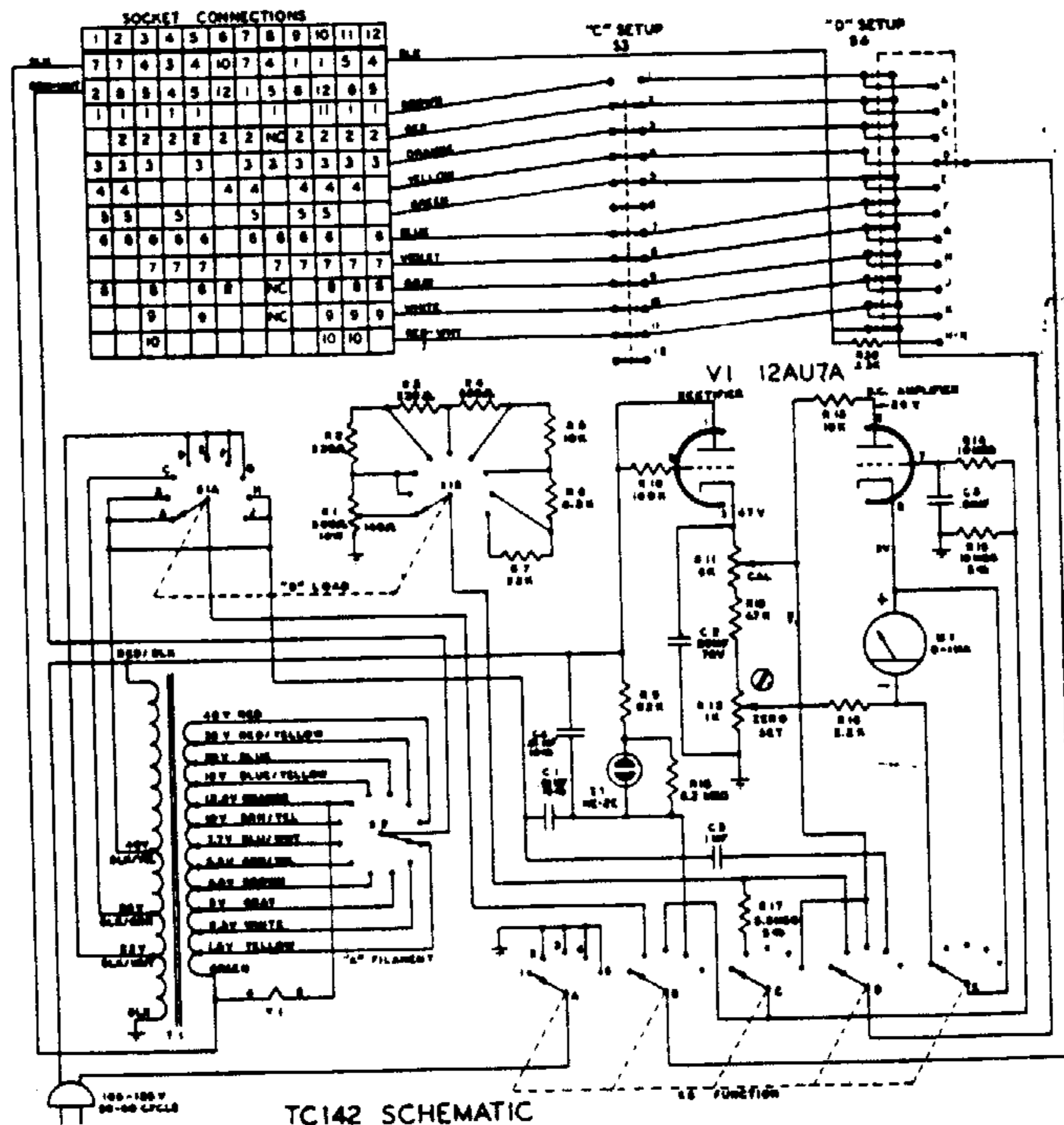

## PARTS LIST

Ref.	Description	Part No.	Price
M1	Meter, 0-1MA	23S12	\$12.00
R1	Resistor, 300 Ohm 10 W tap @140 ohm	14G129	.95
R11	Potentiometer, 6K	15S15A	.75
R12	Potentiometer, 1K	15G20	.70
S1	Switch, Load	25S42A	3.25
S2	Switch, Filament	25S22A	2.00
S3	Switch, "C" setup	25S41A	5.95
S4	Switch, "D" setup	25S43A	3.25
S5	Switch, Function	25S40B	3.25
T1	Transformer filament	28S10A	9.95
Socket 11	Socket, 10 pin	25G54	.50
Socket 12	Socket, Magnoval	26G66	.50

# SENCORE, INC.

426 S. WESTGATE DRIVE, ADDISON, ILLINOIS